

Door Width 16' - 2" Shown
See chart below for other door widths

NOTE: Track configuration above the door opening does not affect the wind load rating of the door.

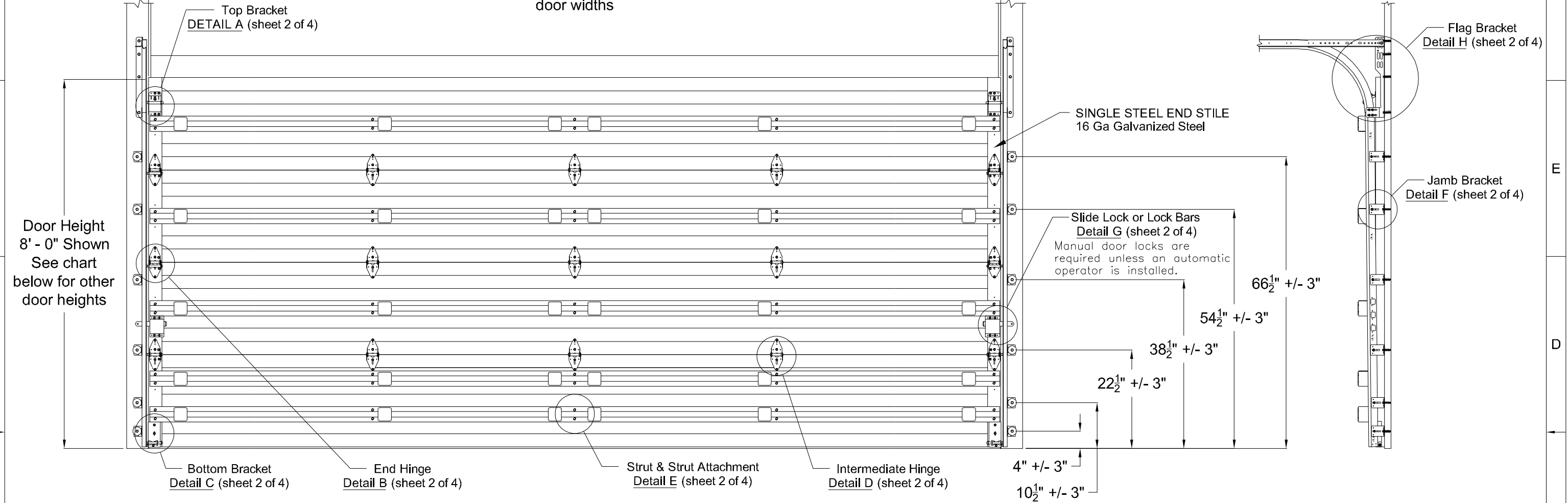

Door Height 8' - 0" Shown
See chart below for other door heights

This product has been evaluated per ANSI/DASMA 108 for static air pressure.
This product has been evaluated per ANSI/DASMA 115 for large missile impact and cyclic wind pressure.

Jamb bracket quantities shown are for use with grade 2 or better southern pine jambs.
Supporting structural elements are to be designed by a registered professional engineer for specific wind loads.

		Model Number					
		HT_60 & 2_60 SERIES		HT_10 & 2_10 SERIES			
		HT_61 & 2_61 SERIES		HT_12 & 2_12 SERIES			
		HT_63 & 2_63 SERIES		HT_14 & 2_14 SERIES			
		HT_64 & 2_64 SERIES		HT_16 & 2_16 SERIES			
		HT_70 & 2_70 SERIES		HT_18 & 2_18 SERIES			
		HT_71 & 2_71 SERIES		HT_20 & 2_20 SERIES			
HT_80 & 2_80 SERIES		HT_72 & 2_72 SERIES		HT_22 & 2_22 SERIES			
HT_81 & 2_81 SERIES		HT_73 & 2_73 SERIES		HT_24 & 2_24 SERIES			
HT_82 & 2_82 SERIES		HT_74 & 2_74 SERIES		HT_26 & 2_26 SERIES			
HT_90 & 2_90 SERIES		American Tradition 900/9000 SERIES		HT_28 & 2_28 SERIES			
				HT_30 & 2_30 SERIES			
				HT_32 & 2_32 SERIES			
				HT_33 & 2_33 SERIES			

Door Widths Up To	Design Pressures		End Backers	Minimum Center Stiles		Minimum Center Hinges		Minimum Center Stiles		Minimum Center Hinges		Impact Resistant
	+ psf	- psf		Stiles	Hinges	Stiles	Hinges	Stiles	Hinges			
10'-2"	31.3	-34.9	Single	2	2	1	1	2	2	2	2	YES
12'-2"	31.3	-34.9	Single	2	2	2	2	2	2	2	2	YES
14'-2"	31.3	-34.9	Single	4	4	2	2	3	3	3	3	YES
16'-2"	31.3	-34.9	Single	3	3	3	3	3	3	3	3	YES

Door Height	Total # of Sections	Total # of Struts	Jamb Brkts per Side
6'-0"	3	4	5
6'-0"	4	5	5
6'-3"	4	5	5
6'-6"	4	5	6
6'-9"	4	5	6
7'-0"	4	5	6
7'-3"	4	5	6
7'-6"	4	5	6
7'-6"	5	6	6
7'-9"	4	5	6
7'-9"	5	6	6
8'-0"	4	5	6
8'-0"	5	6	6

NOTICE:
These drawings are a supplement to the installation instructions for a standard door and only covers those procedures that vary from standard door installation. If these specific procedures are not followed, the door may not perform as designed.

Maximum section height is 24 in.
Maximum door height is 20 ft.
All doors, even those above the tested height, are available with jamb brackets or commercial full angle. The maximum spacing of the jamb brackets/track clips should be maintained.

IMPACT RESISTANT

COMPLIES WITH IBC/IRC 2018 Professional Engineer seal provided only for verification of wind load construction details.

John E. Scates, P.E.
2560 King Arthur Blvd. Ste 124-54
Lewisville, Texas 75056
Texas P.E. 56308/F2203

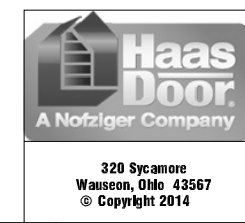

DESCRIPTION: 16' 2" HT 600, 700, 2000, 800 & 900/9000 AMERICAN TRADITION SERIES WIND LOAD SECTIONAL DOOR DESIGN PRESSURE +31.3/-34.9 PSF			
DRAWING NO.: WLT-0600-0194-08-31-35	REV.: A		
DRAWN BY: MVS	DATE DRAWN: 10/25/18	REV. DATE: 2/28/22	
MODEL(S): See Sheet 3	SHEET: 1 OF 4		

This product is available in narrower sizes with the same PSF and constructed as shown.
This product is designed and sold by PSF. The AHJ or Engineer of Record is responsible for determining the PSF required for any given site.

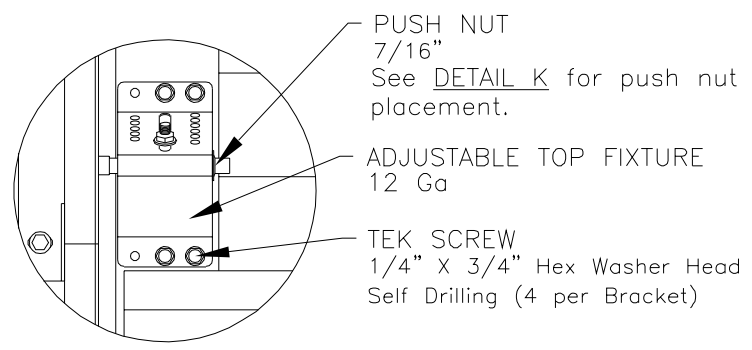

DETAIL A

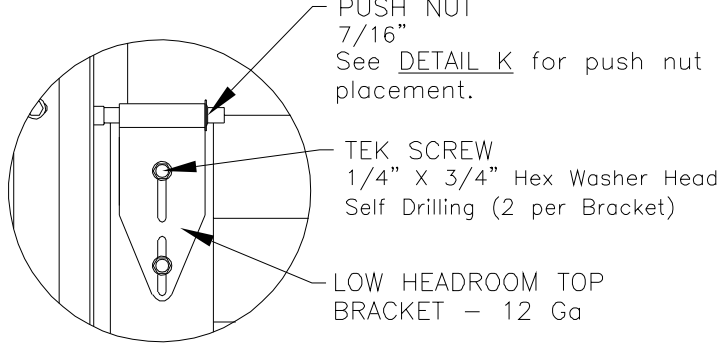

LOW HEADROOM TOP BRACKET

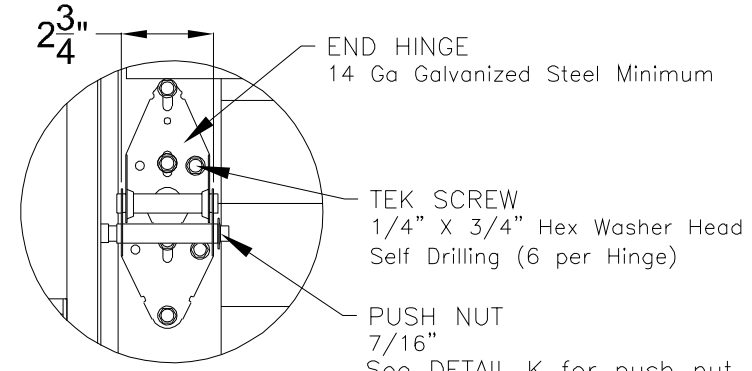

DETAIL B

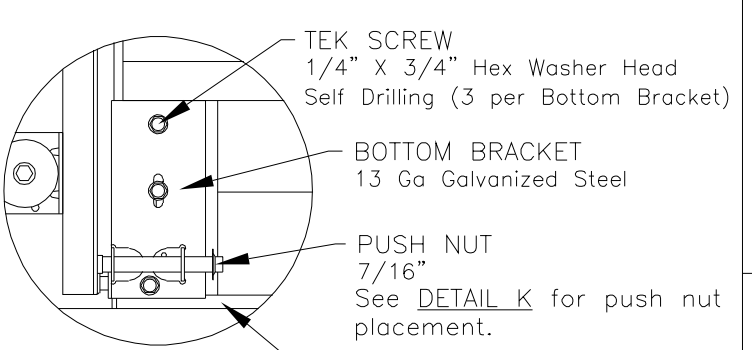

DETAIL C

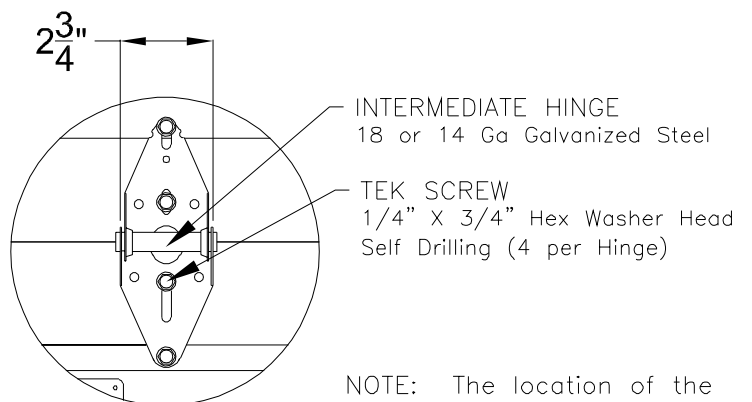

DETAIL D

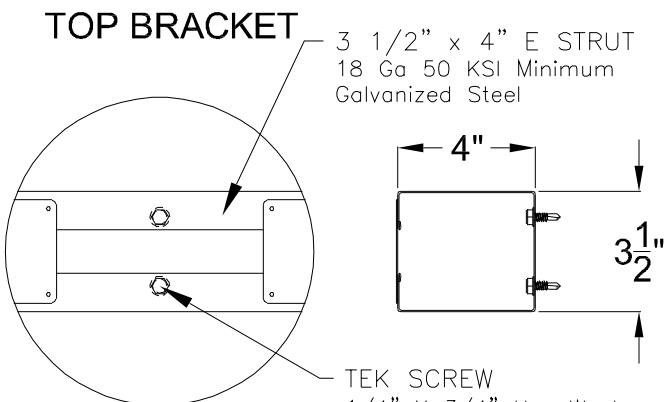

DETAIL E

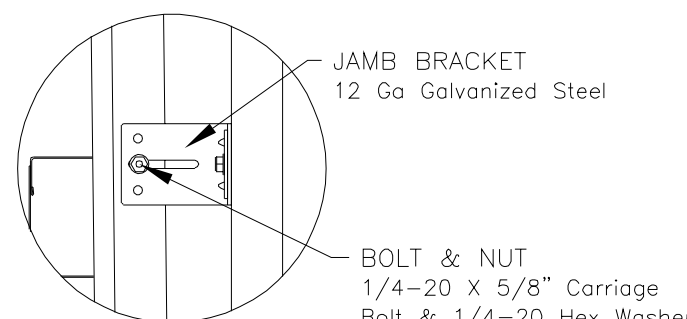

DETAIL F

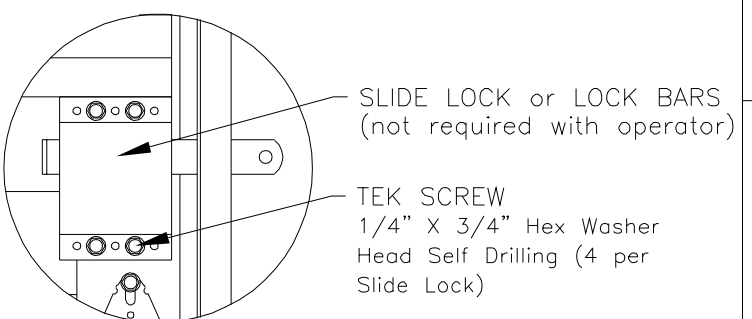

DETAIL G

NOTE: The location of the intermediate hinges is indicated by the toggle lock dimples at the top of each section.

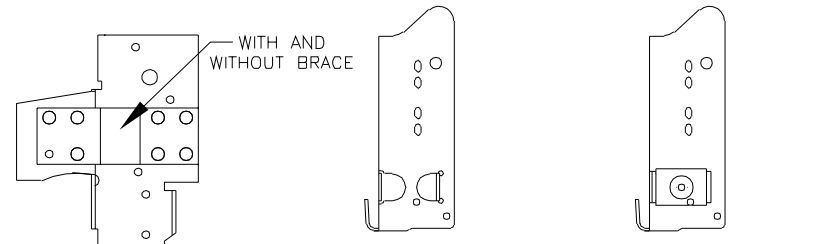

RESIDENTIAL & LIGHT COMMERCIAL
For Low Headroom With 2" Track and Single End Stiles

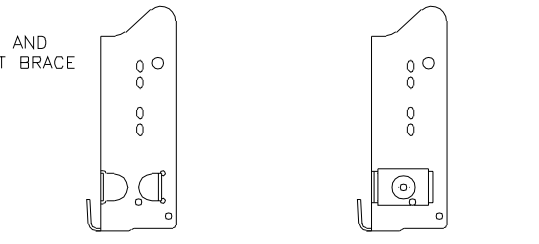

COMMERCIAL For Standard, High & Vertical Lift With 2" Track and Single End Stiles

COMMERCIAL For Standard, High & Vertical Lift With 3" Track and Single End Stiles

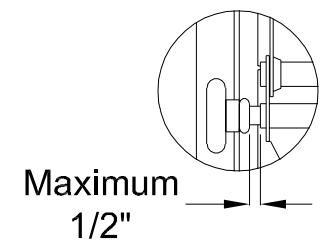

DETAIL K

There should be a space of maximum 1/2" between the roller hub and the outside edge of the roller holder which is set by the push nut.

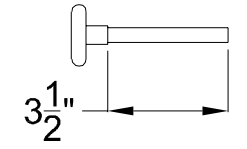

ROLLER

2" Diameter Nominal Eleven Ball Nylon or Ten Ball Steel with a Minimum Workable Shaft Length Shown.

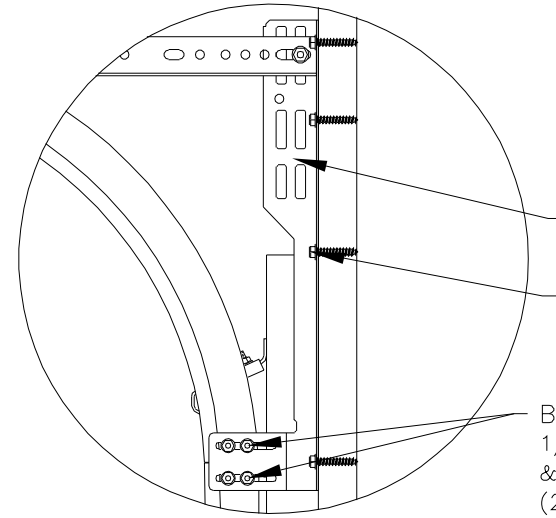

DETAIL H

NOTE: Details on some views omitted for clarity. Double end stiles and end hardware may be provided on wider or heavier doors.

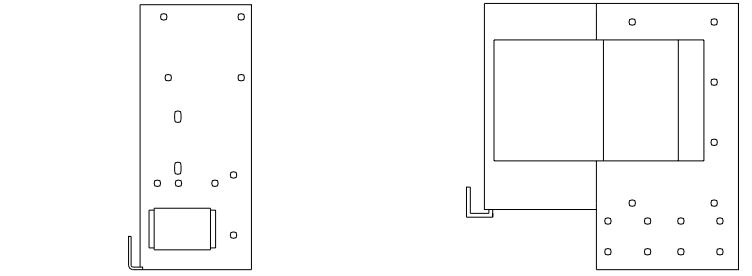

COMMERCIAL HEAVY DUTY For Standard, High & Vertical Lift With 3" Track and Double End Stiles

COMMERCIAL HEAVY DUTY For Low Headroom With 3" Track and Double End Stiles

ALTERNATE BOTTOM BRACKETS

NOTE: The bottom bracket tested (shown in DETAIL C) is the lightest bracket available.

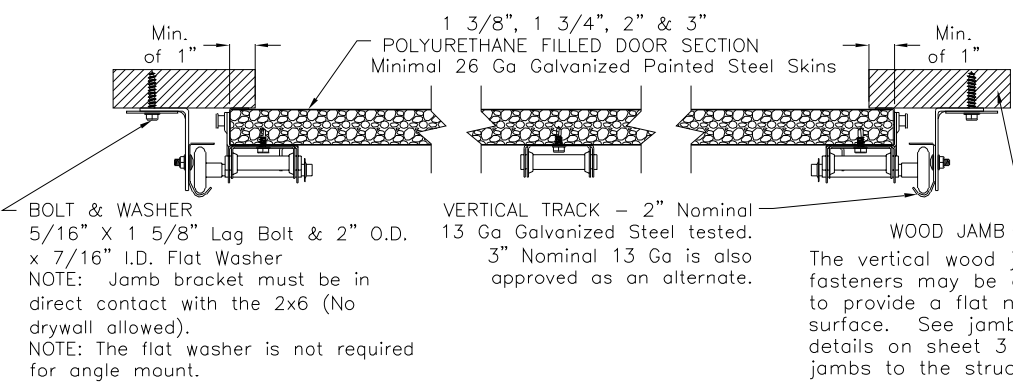

IMPACT RESISTANT

John E. Scates, P.E.
2560 King Arthur Blvd. Ste 124-54
Lewisville, Texas 75056
Texas P.E. 56308/F2203

Professional Engineer seal provided only for verification of wind load construction details.



DESCRIPTION: 16' 2" HT 600, 700, 2000, 800 & 900/9000 AMERICAN TRADITION SERIES WIND LOAD SECTIONAL DOOR DESIGN PRESSURE +31.3-34.9 PSF			
DRAWING NO.: WLTI-0600-0194-08-31-35	REV.: A		
DRAWN BY: MVS	DATE DRAWN: 10/25/18	REV. DATE: 2/28/22	
MODEL(S): See Sheet 3	SHEET: 2 OF 4		

320 Sycamore
Wauseon, Ohio 43567
© Copyright 2014

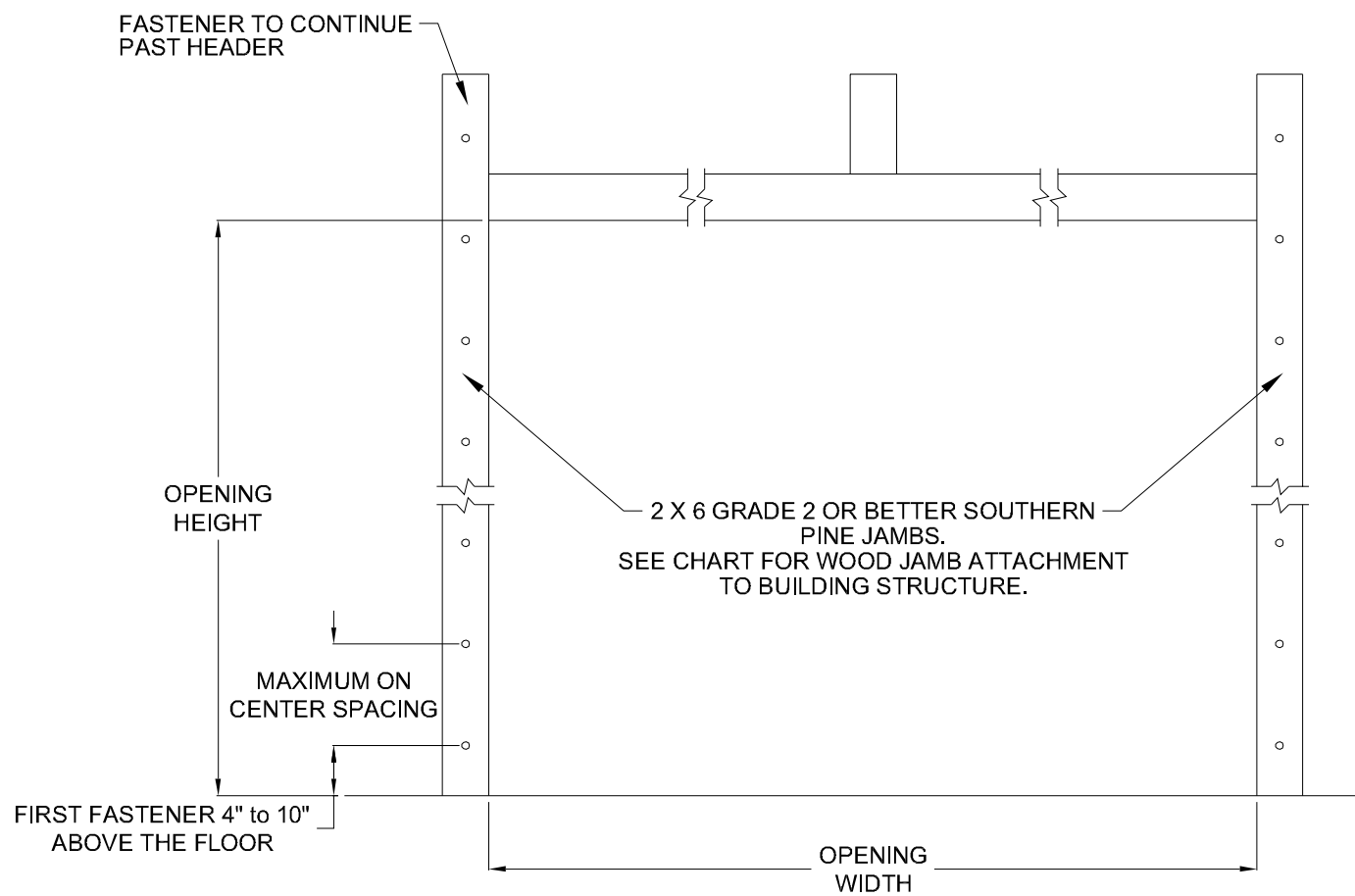

WOOD JAMB ATTACHMENT						
Building Structure	Fastener Type	Minimum Embedment	Minimum Edge Distance	Minimum on Center Spacing	Maximum on Center Spacing	Allowable Tension Load
Min. 2500 PSI to 4000 PSI Concrete	Tapcon + (PLUS) 1/4" w/ 1" OD washer	2"	2.50"	5.00"	24"	551
Southern Pine	3/8" Lag w/ 1 1/8" OD washer	1.50"	1.50"	1.50"	24"	620
Spruce Pine Fir	3/8" Lag w/ 1 1/8" OD washer	1.50"	1.50"	1.50"	22"	482

NOTE: 2X6 mounted to the wall must be Southern Pine Grade 2 or better.

MODEL NUMBERS

MODEL NUMBERS AVAILABLE
HT_14 & 2_14 SERIES
HT_16 & 2_16 SERIES
HT_32 & 2_32 SERIES
HT_33 & 2_33 SERIES
HT_10 & 2_10SERIES
HT_12 & 2_12 SERIES
HT_60 & 2_60 SERIES
HT_61 & 2_61 SERIES
HT_63 & 2_63 SERIES
HT_64 & 2_64 SERIES
HT_70 & 2_70 SERIES
HT_71 & 2_71 SERIES
HT_72 & 2_72 SERIES
HT_73 & 2_73 SERIES
HT_74 & 2_74 SERIES
HT_80 & 2_80 SERIES
HT_81 & 2_81 SERIES
HT_82 & 2_82 SERIES
HT_90 & 2_90 SERIES
American Tradition 900/9000 SERIES

IMPACT RESISTANT

John E. Scates, P.E.
 2560 King Arthur Blvd. Ste 124-54
 Lewisville, Texas 75056
 Texas P.E. 56308/F2203

Professional Engineer seal provided only for verification of wind load construction details.



DESCRIPTION:
 16' 2" HT 600, 700, 2000, 800 & 900/9000 AMERICAN TRADITION SERIES WIND LOAD SECTIONAL DOOR DESIGN PRESSURE +31.3/-34.9 PSF

DRAWING NO.: WLTI-0600-0194-08-31-35	REV.: A
DRAWN BY: MVS	DATE DRAWN: 10/25/18
REV. DATE: 2/28/22	
MODEL(S): See Sheet 3	SHEET: 3 OF 4

320 Sycamore
 Wauseon, Ohio 43567
 © Copyright 2014

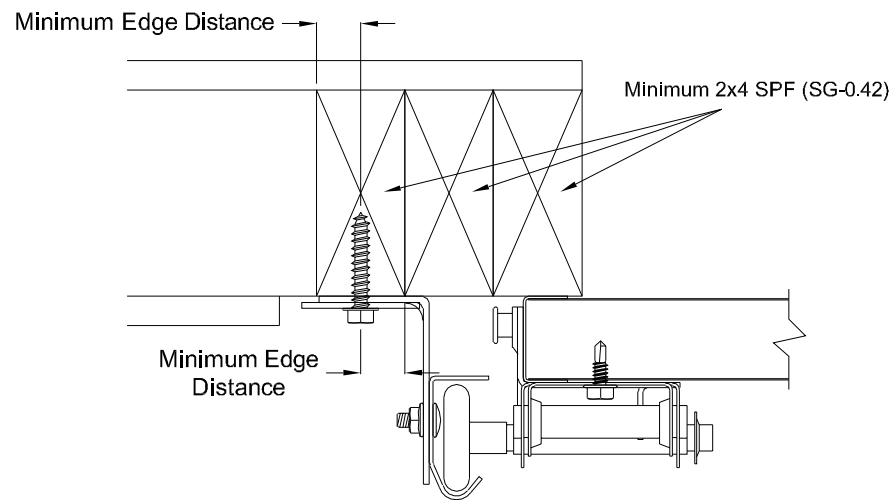

Direct Wood Mounting Detail

Bracket Mount Shown, Reverse and Continuous Angle Mount Also Approved As Alternate.

439 lbs. per anchor allowable load

5/16" Dia. Lag Screw w/1-1/8" O.D. Flat Washer (shall conform to ANSI/ASME standard B18.2.1)

Minimum Screw Length: Spruce-Pine-Fur (SPF) - 2-1/2"
Southern Pine - 1-5/8"

Minimum Edge Distance: 1/2"

Maximum on Center Spacing: 21"

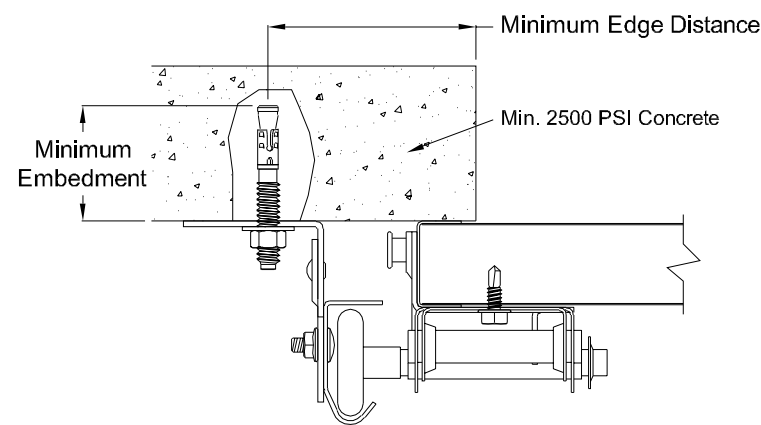

Direct Concrete Mounting Detail

Continuous Angle Clip Mount Shown, Bracket and Reverse Continuous Angle Mount Also Approved As Alternate.

831 lbs. per anchor allowable load

3/8" Dia. Ankr-Tite CCAT w/1-1/8" O.D. Flat Washer (by Wej-It Fastening Systems)

Minimum Embedment: 2-5/8"

Minimum Edge Distance: 2-1/2"

Minimum on Center Spacing: 6"

Maximum on Center Spacing: 24"

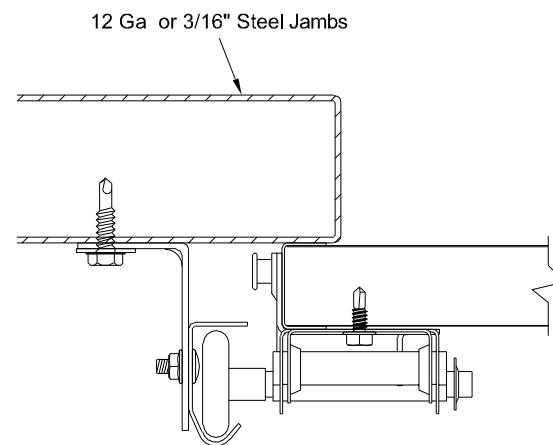

Direct Steel Mounting Detail

Bracket Mount Shown, Reverse and Continuous Angle Mount Also Approved As Alternate.

232 lbs. per anchor allowable load - 12 Ga Steel

569 lbs. per anchor allowable load - 3/16" Ga Steel
5/16"-12 Tek Self-Drilling Screw w/9/16" O.D. Flat Washer

12 Ga Maximum on Center Spacing: 11"

3/16" Maximum on Center Spacing: 24"

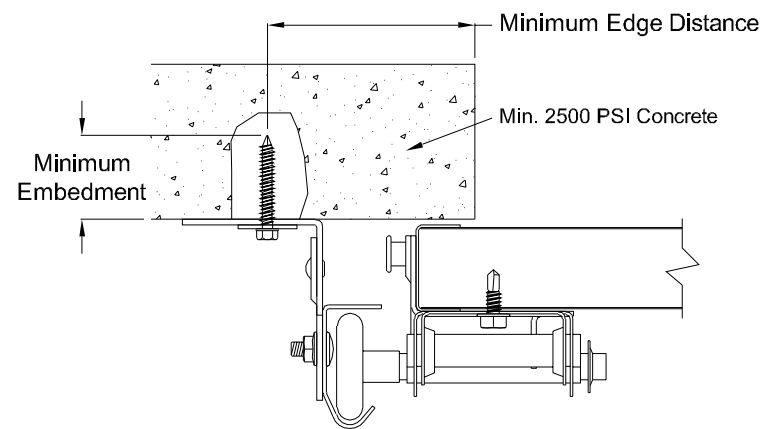

Direct Concrete Mounting Detail

Continuous Angle Clip Mount Shown, Bracket and Reverse Continuous Angle Mount Also Approved As Alternate.

562 lbs. per anchor allowable load

1/4" Dia. Concrete Self-Tapping & Wedge Anchor w/1" O.D. Flat Washer (Includes Tapcon+ (by ITW), Wedge-Bolt+ (by Powers Fasteners) & Red Head

TruBolt wedge anchor (by ITW))

Minimum Embedment: 2"

Minimum Edge Distance: 2-1/2"

Minimum on Center Spacing: 5"

Maximum on Center Spacing: 24"

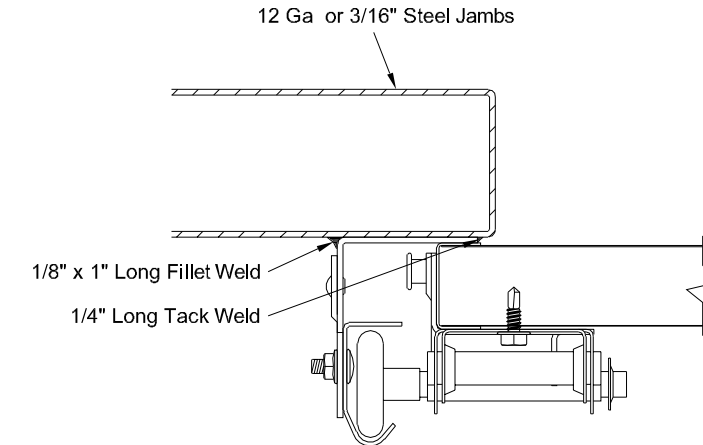

Direct Steel Mounting Detail

Reverse Continuous Angle Clip Mount Shown, Continuous Angle Mount Also Approved As Alternate.

1272 lbs. per anchor allowable load

1/8" Nom. x 1" Long Fillet and 1/4" Long Tack Weld (E60xx Electrodes Min.)

Welds performed by a certified welder or inspected by a certified welding inspector to verify integrity of the welds.

Maximum on Center Spacing: Apply welds at each roller location not to exceed 24"

IMPACT RESISTANT

John E. Scates, P.E.
2560 King Arthur Blvd. Ste 124-54
Lewisville, Texas 75056
Texas P.E. 56308/F2203

Professional Engineer seal provided only for verification of wind load construction details.



DESCRIPTION:
16' 2" HT 600, 700, 2000, 800 & 900/9000 AMERICAN TRADITION SERIES WIND LOAD SECTIONAL DOOR DESIGN PRESSURE +31.3/-34.9 PSF

DRAWING NO.: WLTI-0600-0194-08-31-35 **REV.:** A

DRAWN BY: MVS **DATE DRAWN:** 10/25/18 **REV. DATE:** 2/28/22

MODEL(S): See Sheet 3 **SHEET: 4 OF 4**

320 Sycamore
Wauseon, Ohio 43567
© Copyright 2014